

Warnings

The Lowel Fluo-Tec fluorescent studio line is a professional lighting system. Read these instructions and lamp manufacturers warnings before operating. See Back Cover for important fuse information.

- **Do not leave fixture unattended.**
For stationary (studio) use.
- **Not for household use.**
Use only for photographic lighting (video & film imaging).
- **Do not exceed maximum rated wattage for unit.**
- **Use maximum 55 Watt lamps.**
- **Always unplug unit before relamping.**
- **Always unplug unit before changing fuse.**
- **Be sure lamp is securely seated in lamp socket.**
- **Do not use near standing water.**
- **Internal ballasts produce high start-up voltage.**
- **Never bypass plug's ground pin.**
- **Do not interfere with unit's ventilation.**
- **Do not operate unit with Barndoors closed.**
- **Make sure clamp is tightened at yoke.**
- **Always use Safety Cables,** when attaching to overhead pipes or grids.
- **Do not attempt to open unit,** no user serviceable parts inside.
- **Always use with supplied Lowel AC Cable.**

Fluorescent Warnings

- **Avoid looking directly at the tubes** for extended periods of time.
- **Fluorescent tubes contain highly poisonous mercury.**
- **In the event of lamp breakage,** avoid contact with broken pieces, and dispose of properly.
- **Read lamp manufacturers information fully.**

Contents

Using Lowel Fluo-Tec Front Accessories	2
Lowel Fluo-Tec Models & Control Panel	3
Lamps & Fuse Change	4
Fuses & Power Consumption	4
Mounting the Fixture	4
Problems, repairs & info	4

Each fixture comes with:

- Gel frame
- 3 safety cables
- Standard C Clamp yoke mounting device
- Standard AC power cable with male Edison connector

Accessories

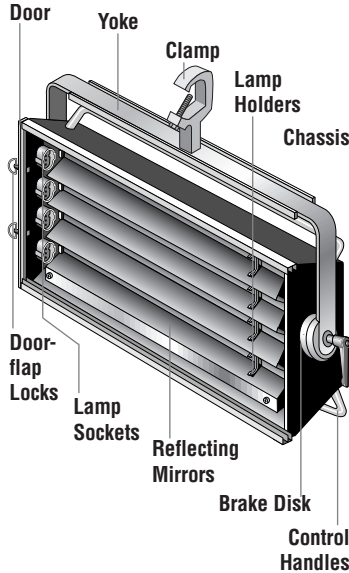

Dimmable Models

- Studio 250DM
- Studio 250cyDM
- Studio 450DM
- Studio 650DM
- Studio 850DM

Phase Dimmable Models

- Studio 250PHD
- Studio 250cyPHD
- Studio 450PHD
- Studio 650PHD
- Studio 850PHD

Non-dimmable Models

- Studio 250ND
- Studio 250cyND
- Studio 450ND
- Studio 650ND
- Studio 850ND

Lowel Fluo-Tec Models

- Studio 250DM
- Studio 250PHD
- Studio 250ND

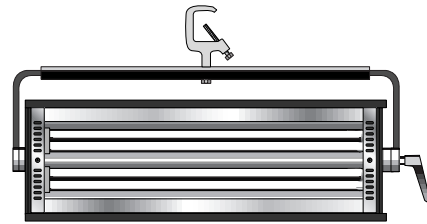

- Studio 450DM
- Studio 450PHD
- Studio 450ND

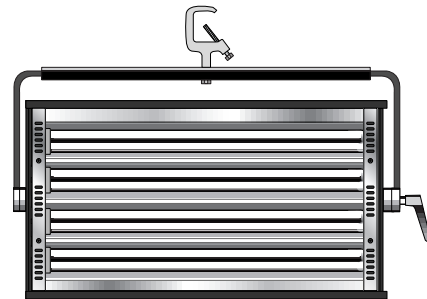

- Studio 650DM
- Studio 650PHD
- Studio 650ND

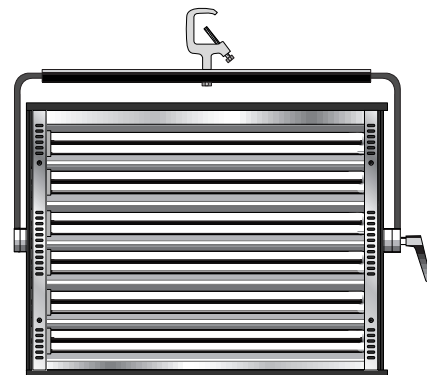

- Studio 850DM
- Studio 850PHD
- Studio 850ND

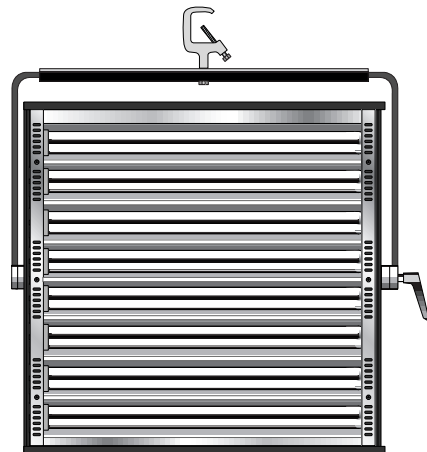

- Studio 250cyDM
- Studio 250cyPHD
- Studio 250cyND

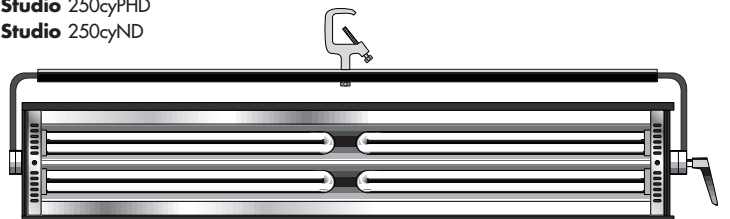

Using Lowel Fluo-Tec Front Accessories

Front Accessories

Intensifier:

The mirrored Intensifier, when attached, can almost double the light output of the fixture. Assemble before attaching to light. Intensifier is a one piece unit that unfolds and locks together at its corners. Take care to make sure that all quarter-turn locks are securely fastened. Slide assembled intensifier into front slot of fixture, close doorflap and secure twist-locks. Note - Intensifier has grooved slot on front for attachment of Honeycomb Grid to trim light. Choose correct size of Honeycomb Grid.

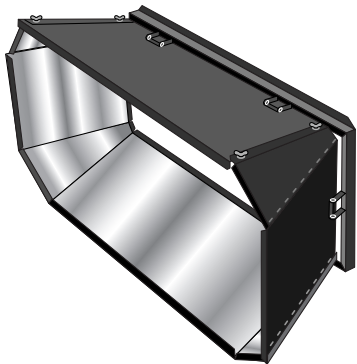

Honeycomb Grid:

Each fixture has 2 options for using honeycomb grids to control the spill of the light, either placing a grid on the front of the fixture, or attaching one to the front of the Intensifier. Because the front of the intensifier is a different size & shape than the front of the fixture, there are specific models for each use. It is not possible to use the "front of fixture" grid with the Intensifier installed. The grids are available in black with 20, 30, or 40 degree dispersions. **If you are at all unsure of which honeycomb to use, contact us.** Honeycomb Grids cause some loss of light output (see chart).

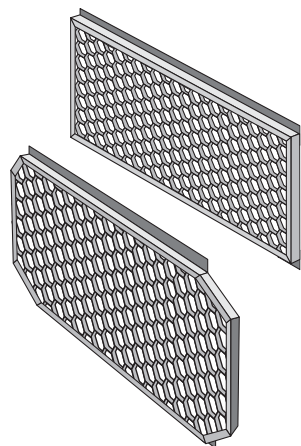

Gel Frame:

For using colored or diffusion gels in front of the fixture to change the color of the light or to diffuse it further. Slide the pre-cut gel material into the hinged frame, taking care to trim any excess that falls outside the frame. Slide the frame into the slot closest to the lamps on the front of the fixture. Close & tighten locking door-flap of the fixture.

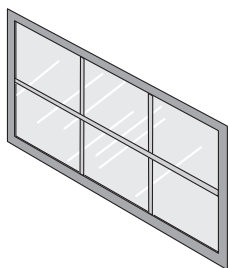

Egg Crates:

for controlling spill. Slide the Egg Crate into the front accessory slot. Less control than Honeycomb Grid, with less output loss.

Barndoors:

For trimming spill of the light, slide Barndoor assembly into front slot on fixture, close door-flap and secure twist-locks. Open doors and adjust for proper trimming of spill. Do not operate unit with Barndoors closed.

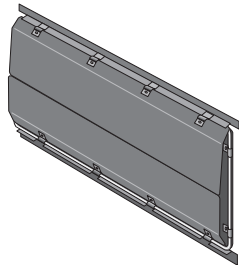

Slide-in Slots

There are 2 slots in front of the fixture for slide-in attachment of Front Accessories.

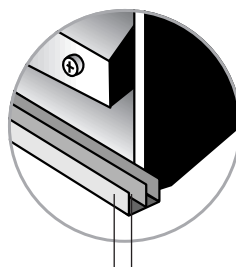

Slot B Slot A

Slot A

closest to the lamps is for slide-in attachment of the Gel Frame accessory

Slot B

furthest from the lamp is for attachment of all other accessories.

Slots are accessible by releasing the twist locks and opening the door-flap on the front left side

Slots are accessible by releasing the twist locks and opening the door-flap on the front left side

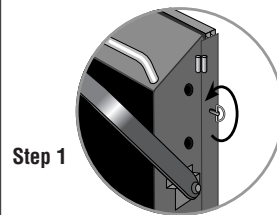

Step 1

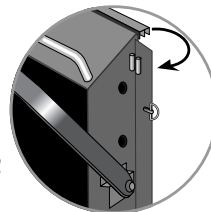

Step 2

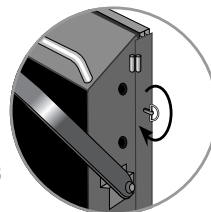

Step 3

Sliding in Accessories

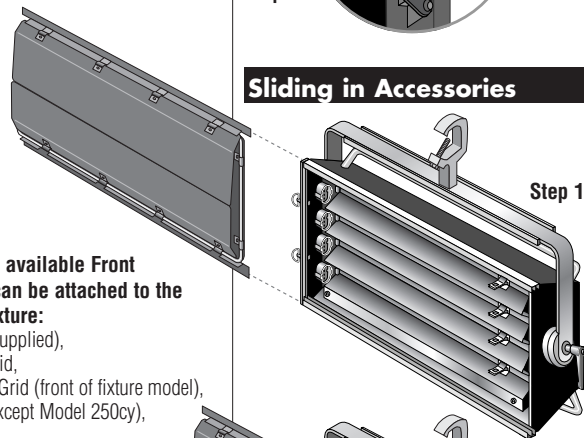

Step 1

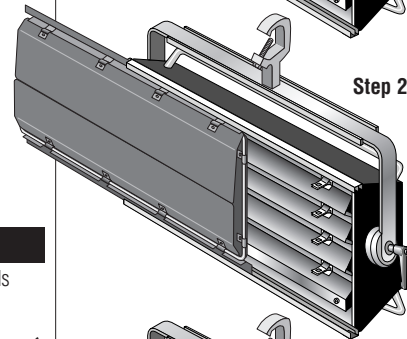

Step 2

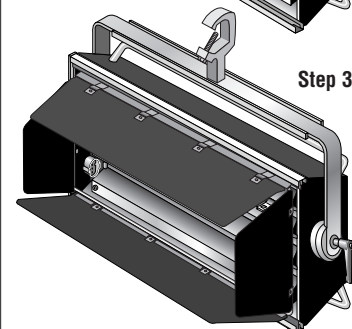

Step 3

The following available Front Accessories can be attached to the front of the fixture:

- Gel Frame (supplied),
- Egg Crate Grid,
- Honeycomb Grid (front of fixture model),
- Intensifier (except Model 250cy),
- Barndoors

Honeycomb Grids Comparison

The grids are black and available in 20, 30, or 40 degree dispersion for the front of the fixture or the front of the Intensifier. Honeycomb Grids cause some loss of light output. Consult the below chart to determine the proper code for the chosen grid.

Dispersion°	Grid Placement	Output Loss	Studio 850	Studio 650	Studio 450	Studio 250	Studio 250cy
Black 40°	Front of Fixture	25%	FLS-834	FLS-634	FLS-434	FLS-234	FLS-2534
Black 30°	Front of Fixture	35%	FLS-833	FLS-633	FLS-433	FLS-233	FLS-2533
Black 20°	Front of Fixture	54%	FLS-832	FLS-632	FLS-432	FLS-232	FLS-2532
Black 40°	Front of Intensifier	30%	FLS-844	FLS-644	FLS-444	FLS-244	N/A
Black 30°	Front of Intensifier	22%	FLS-843	FLS-643	FLS-443	FLS-243	N/A
Black 20°	Front of Intensifier	46%	FLS-842	FLS-642	FLS-442	FLS-242	N/A

Control Panel & Using Dimmable Models

Dimmable Models

The fixtures of the Lowel Fluo-Tec studio line are all available in dimmable models, which can be controlled either manually on the fixture or remotely via DMX-512 protocol (console of IR DMX Controller). To operate the Control Panel, first familiarize yourself with the placement and functions of the controls. Note: Fluorescent systems typically require a minute or 2 to reach full brightness on cold startup, depending on ambient room temperature.

Control Panel Functions AC Power Switch

Turning on the AC Power switch, starts the fixture's dimmer at whatever level it was at when last powered down (factory shipped at 100%). The unit will retain its previous dimming level even if unplugged.

MODE Key/LED Display

Repeated pressing of the MODE Key scrolls the unit thru its various control functions, as displayed in the LED Display window.

MODE displays, in order of appearance:

- 1) Hours of lamp operation,
- 2) Unit dimming level (preceded by **L**),
- 3) Dimming to 0% or 1% (**LP on oF**)
- 4) DMX address (preceded by **A**).

If a valid DMX signal is detected, fixture will automatically display its DMX address (ex. - A1). However if another display MODE is chosen, it will display that mode until the fixture is powered down or DMX signal is lost.

Model & Software Version Display:

When the unit is first powered up, the LED display will scroll the model name of the fixture (ie.—Studio 250cy), followed by the version number of the installed software (ie. r2-3, for version 2.3). Make note of the software version number in case the fixture needs service.

1) Hours:

The manufacturers expected lamp life is approximately 8 - 10,000 hours. The display counts the hours of lamp operation between 0 to 9,999 hours. If the hours pass the 9,999 point, the display will flash 9999 indicating that it is time to change the lamps.

To reset the counter after relamping, while in the Hours mode, hold down the MODE key for over 4 seconds. This resets the counter to 0. To avoid confusion, it is recommended that you replace all lamps in the fixture at the same time if you plan to monitor lamp life with this function.

2) Unit Dimming Level:

This value (preceded by **L**) shows either the level set using the Up/Down Arrows (Manual Mode), the level stored in a selected Memory (1-4), or the level as controlled by the DMX lighting console (DMX Mode). All models have a dimming range from 100% to 0% or 1%, depending on how the fixture is set.

3) Dimming to 0% or 1%

The dimmable models with software revision 2.3 or later can be set to dim fully from 100 to 0%, or from 100 to 1% depending upon user preference.

Fixtures dimmed to a minimum of 1% can be quickly dimmed up full, whereas fixtures dimmed to 0% will experience a brief delay in graceful dimming as the lamps start up.

To set the fixtures, first make sure they are not connected to a DMX chain. Scroll thru the MODE menu on the back of each until you reach "LP on oF" on the LED display. Holding the MODE button for 3 seconds will toggle the function between "LP on" & "LP oF" (Off). "LP on" means the lamp powering will dim down to 0% when control is faded all the way down, and "LP oF" means the lamp powering function is kept at 1% when control is faded all the way down. This setting gets saved inside the fixtures memory, even when powered down, and is in effect regardless of manual or DMX dimming.

4) DMX Address:

DMX-512 protocol allows you to assign one of 512 possible control addresses to the fixture. The letter **A** precedes the DMX Address of the unit.

Up/Down Arrows

Used for moving up or down in numerical value for functions chosen by the MODE key. ex. — manual dimming, DMX Address selection, etc.

MEMORY

The 4 Memory buttons are used to select & recall stored dimmer levels.

Manual Dimming

The dimming level of the fixture is shown with a value that begins with **L**. Manual dimming can be controlled with the Up/Down arrows on the control panel of the fixture, or by the 4 stored Memory settings. The unit will restore its last dimming level, when powered

up even if it has been unplugged. Manual dimming can only happen if the unit is not receiving a valid DMX signal from the console. All models have a dimming range from 100% to 0% or 1%, depending on how the fixture is set.

Using Memories

When using the unit manually (non-DMX operation) there are 4 user-storable dimming memories, which will be saved, even when the unit is turned off and unplugged.

To store a memory setting,

- 1) Bring the fixture to the desired level (for example 72%) using the Up/Down Arrows.
- 2) Hold down the chosen memory key for 4 seconds. The display will flash, and the level will be saved. When you press a memory button, it will recall the setting saved on that memory.

The unit is shipped with 4 factory preset memory settings

- 1 – 25%
- 2 – 50%
- 3 – 75%
- 4 – 100%

To recall a memory setting,

Press a Memory button (1-4) to bring the fixture to its previously stored level.

Dimming (via DMX)

To set or change the DMX address:

- 1) Make sure the unit is not receiving a DMX signal by either turning off console, or disconnecting DMX cable.
- 2) Press the MODE Key repeatedly to scroll the LED to DMX Address.
- 3) Hold down the MODE key for 4 seconds. The DMX address will flash, and you can then set or change that address by using the Up/Down arrows from 1 to 512.
- 4) After selecting the desired DMX address, hold down the MODE key for 4 seconds, and the address will be saved, even when the unit is turned off and unplugged, until it is reset again as described above.

Connecting for DMX Use

To control a single unit using DMX-512, connect a DMX cable between the output of the console and the DMX In connector on the back of the unit.

DMX connections to multiple units must be daisy chained from the console's DMX Out to the 1st unit's DMX In connector, and then from that unit's DMX Out connector to the next unit's DMX In connector, etc. For proper DMX operation, the final unit should have a DMX terminator plugged into its DMX Out connector.

Note: When the unit is receiving a valid DMX signal, the only active function that you can use manually on the rear control panel is the MODE button. You cannot set or recall memories, set the DMX address, change dimming status between 0 & 1%, or reset the lamp hour counter.

DMX Dimming

While you are in DMX mode (as soon as you plug in the console and there is a valid DMX signal), the LED Display will show the DMX Address of the unit. Its level will reflect the intensity sent by the console for that channel. All models have a dimming range from 100% to 0% or 1%, depending on how the fixture is set.

Remote Port

The unit can also be controlled by the optional IR DMX Controller, a handheld wireless IR remote control for use in controlling single or multiple units without the need for a DMX console. See "IR DMX Controller for use with Lowel Fluo-Tec Studio Fluorescent System" instructions, for more information.

Phase Dimmable Models

Phase Dimmable models do not have dimmers installed inside. Instead they have the ability to be dimmed via an AC powered phase dimming system.

Plug the AC cable of fixture into dimmer and power the fixture up, to control via the dimmer.

Non-dimmable Models

All non-dimming models have multiple lamp switches, each controlling 1 pair of lamps (except Studio250). Output can be varied by use of the switches.

Model	Switches x Lamp-pairs
Studio 250	1 x 1
Studio 250cy	2 x 2
Studio 450	2 x 2
Studio 650	3 x 2
Studio 850	2 x 4

Note: Fluorescent systems typically require a minute or 2 to reach full brightness on cold startup, depending on ambient room temperature.

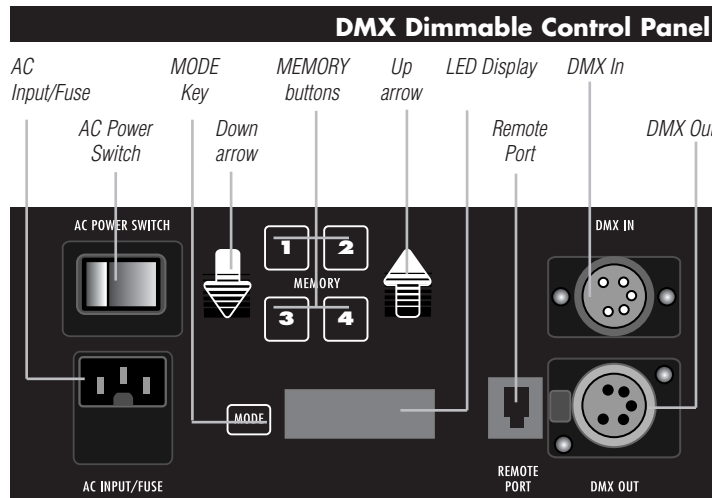

Lamps & Fuse Change

Lowel Fluo-Tec fluorescent studio fixtures use compact (55 watt) fluorescent lamps. See lamp manufacturers specifications for additional information.

Osram Studioline® Lamps (Video/Digital)

Designed for use in video & digital imaging for more accurate color rendering and higher output. Mixes with tungsten/ halogen sources. Mfrs rated life - 8,000 hrs.

Tungsten	CRI	Color Temp.
FL-550TU Studioline 55w/3200	85	3000° K
Daylight	CRI	Color Temp.
FL-550DA Studioline 55w/5600	85	5600° K

GE Cinema-Plus Lamps (Film)

Better lighting for film (still or motion picture) due to better color rendering with film emulsions. May require 1/8 "minus green" filtration gel. Mfr. rated life - 8,000 hrs

Tungsten	CRI	Color Temp.
FLC-55TU* GE F55BX/CINPLUS32	90+	3200° K
Daylight	CRI	Color Temp.
FLC-55DA* GE F55BX/CINPLUS55	90+	5500° K

Lamp Installation & Change

Facing the fixture, the base of the lamps are on the left side (except for model 250cy which has lamp bases on both sides). To remove a tube, gently grasp it by the glass end (furthest from socket) and swing it slightly out from the spring clamp that holds the center of the lamp tube, away from the fixture while pulling it carefully straight out from the socket. Replace lamp in same way, opposite order. (Be very careful as lamp-tubes are fragile and can easily shatter, read Warnings).

Fuse Change

All fixtures come with a user-replaceable mini-fuse which is installed in a small holder on the exterior AC power socket. Access the fuse by removing the cap with a small flathead screwdriver. Swap fuse if necessary and replace holder. Consult the chart on page 2 or the back label the fixture to confirm proper replacement fuse.

Fuses & Power Consumption

Note - Most electrical equipment briefly consumes a higher amount of electrical current during startup (ignition). Consult the below chart to confirm that your electrical wiring is sufficient for the fixtures used. All fuses must be rated at 250VAC.

120 Volt Model 50/60Hz

DMX Dimmable Models

Integral ballast operating frequency:

40-60 KHz

Power factor: >97

Model	Fuse	Nominal Current	Peak Ignition Current
850DM	6.30 A	4.02 A	6.00 A
650DM	5.00 A	2.96 A	4.00 A
450DM	3.15 A	2.00 A	3.00 A
250DM	1.60 A	1.05 A	1.50 A
250cyDM	3.15 A	2.00 A	3.00 A

Phase Dimmable Models

Integral ballast operating frequency:

40-60 KHz

Power factor: >97

Model	Fuse	Nominal Current	Peak Ignition Current
850PHD	8 A	5.42 A	12.30 A
650PHD	6.3 A	3.80 A	8.36A
450PHD	5 A	2.70 A	6.80 A
250PHD	5 A	1.48 A	4.10 A
250cyPHD	5 A	2.70 A	6.80 A

Non-dimmable Models

Integral ballast operating frequency:

26 KHz

Power factor: >70

Model	Fuse	Nominal Current	Peak Ignition Current
850ND	10.00 A	4.52 A	9.90 A
650ND	8.00 A	3.41 A	7.80 A
450ND	5.00 A	2.26 A	5.00 A
250ND	3.15 A	1.15 A	3.00 A
250cyND	5.00 A	2.26 A	5.00 A

Mounting the Fixture

On Lighting Rail: Attach clamp tightly to yoke of fixture, according to clamp mfrs. instructions. Hang clamp on pipe or grid and tighten the large screw so that the clamp and fixture are securely mounted. Do not loosen bolt attaching clamp to fixture, to position light. Attach 1 or more safety cables between the fixture and the rail for necessary security.

On Stand: There are 2 options for stand mounting of the fixture, using the 5/8" female stand fitting or using the optional Male Stud. Choose proper size stand for fixture. For all models, the Lowel Grand Stand or larger is preferred, however the following stands may also be used. Always use sufficient stabilizing weight on stand base.

Female 5/8" Stand-fitting: For use on stand only. Allows mounting the fixture on 5/8" male stand stud. Make sure the stand is large enough to support the weight of the fixture while maintaining good balance at the desired height. Attach the female stand-fitting tightly to the yoke and rotate yoke so it is on the underside of the fixture. Tighten yoke, clamp and place female stand-fitting over stand, making sure that its locking screw is loosened enough to allow the fitting to completely fit over the 5/8" stand stud. Tighten screw, making sure it is under the safety cut of the stand fitting stud. Add additional weight to base of stand for increased stability.

Male Stud: For use of fixture with Matthews style stands that have a female cup instead of a male stud. Attach the optional Male Stud in the same manner as described above for Female 5/8" Stand Fitting, again rotating the yoke to the underside of the fixture and tightening yoke clamp. Carefully place Male Stud into female cup on stand top and tighten. Add additional weight to stand base for increased stability.

Model	Lowel Stand
250cy	Do not use on stand
250	KS or KSA
450	KSA
650	Grand Stand*
850	N/A**

*Do not use with top stage extended
**Use appropriate full sized studio stand.

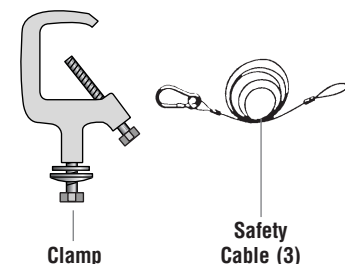
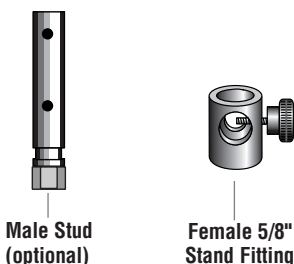

230 Volt Model 50/60Hz

Dimmable Models

Integral ballast operating frequency:

40-60 KHz

Power factor: >98

Model	Fuse	Nominal Current	Peak Ignition Current
850DM230	3.15 A	2.10 A	3.00 A
650DM230	2.50 A	1.60 A	2.30 A
450DM230	1.60 A	1.10 A	1.60 A
250DM230	1.00 A	0.60 A	0.80 A
250cyDM230	1.60 A	1.10 A	1.60 A

Non-dimmable Models

Integral ballast operating frequency:

40-60 KHz

Power factor: >98

Model	Fuse	Nominal Current	Peak Ignition Current
850ND230	3.15 A	2.00 A	2.80 A
650ND230	2.50 A	1.50 A	2.10 A
450ND230	1.60 A	1.00 A	1.50 A
250ND230	1.00 A	0.50 A	0.80 A
250cyND230	1.60 A	1.00 A	1.50 A

Problems, repairs & info

Repairs, problems, suggestions and requests for brochures/catalogs, instructions and parts lists can be handled through your Authorized Lowel Dealer/Distributor or directly through Lowel. Electrical repairs should be made only by Lowel or by a qualified electrician.

Lowel Fluo-Tec equipment is the product of the ongoing collaborative relationship between Fluo-Tec and Lowel-Light Mfg., Inc.

Fluo-Tec is a registered trademark of Fluo-Tec.

Specifications subject to change without notice.



ver. 4.0 © Lowel-Light Mfg., Inc 2010 355

Lowel-Light Manufacturing, Inc.

90 Oser Avenue, Hauppauge, N.Y. 11788
Call: 800 645-2522 or 631-273-2500
Fax: 631-273-2557
e-mail info@lowel.com
www.lowel.com

